

# WSP-2018 BREMEN 9

## 1:50 SCALE RC KIT

ITEM NO: 90390

### READ BEFORE ASSEMBLY:

\* This kit is not recommended for inexperienced modelers or for children under 16 years of age.  
 \* Study and understand these instructions thoroughly before beginning assembly.  
 \* When needed, remove photo-etch parts carefully using a modeling knife or photo etch sprue cutter, being careful not to damage or lose small parts.  
 \* Take extra care in handling photo etch parts in order to avoid injury.  
 \* Apply instant cement sparingly to photo etch parts where instructed.  
 \* Tools recommend(not included in kit):Plastic and instant cements,sprue cutters,long nose pliers,modeling knife,small files,tweezers,pin vise & scissors.Soft cloth and sandpaper will also assist in construction.  
 \* Glue and paint are not included in the kit. Use plastic cement and hobby paints only. Color guide for purchasing paint is included in the kit.  
 \* Keep out of reach of children. They must not be allowed to ingest small parts or handle plastic bags in any way.

### 装配之前仔细阅读

\* 小心用模型锉刀挫平所有零件表面的注塑浇口。  
 \* 小心用刀片切下蚀刻片零件，不要遗失小零件。  
 \* 用强力快干胶水粘合蚀刻片零件和金属轴。使用过量的快干胶水可能导致可动零件被粘住，小心涂胶。  
 \* 取蚀刻片时应特别注意安全，防止利边划伤手指。  
 \* 某些零件表面需贴水贴纸，请在装配时同时进行。  
 \* 推荐模型工具（自备）：胶水，水口剪刀，长咀钳，刀片，锉刀，镊子，钳，钻，剪刀，瞬间快干胶，软布和砂纸。  
 \* 请使用塑料胶水和油漆，模型内不含。  
 \* 谨防小孩吸吮塑料零件，或者将塑料袋套在头上，制作时应将套材远离小孩。  
 \* 本产品不适合没有经验的模型爱好者以及16岁以下的儿童。

### DECAL APPLICATION

1.Cut decals from Sheet as needed  
 2.Dip the decal in warm water for about 10 seconds and then place on soft clean cloth  
 3.Hold the decal backing sheet edge and gently slide the decal onto the model in its proper position.  
 4.While still wet,decal can be adjusted for better fit on model by dampening it gently with your finger  
 5.When placed in the proper position,gently press decal down with a soft cloth until excess water and air bubbles are gone.  
 6.Allow decal to dry completely before handling model.

### 贴纸的使用:

1.从水贴纸上剪下印花;  
 2.将印花放入温水中浸10秒,然后放在干净布上。  
 3.拿着印花纸边缘将印花移到模型上;  
 4.手指蘸水将印花移到适当的位置;  
 5.用软布轻压印花直至水干,气泡消失;  
 6.待印花纸完全干燥后再使用船模。

### 工具建议: Tools Recommendation:

- AC glue 使用强力胶
- File / Sand 锉平
- Drill 钻孔
- Bend 弯曲
- Solder 焊接
- Decal 贴纸
- Cut / Remove 切除
- Ballast 配重

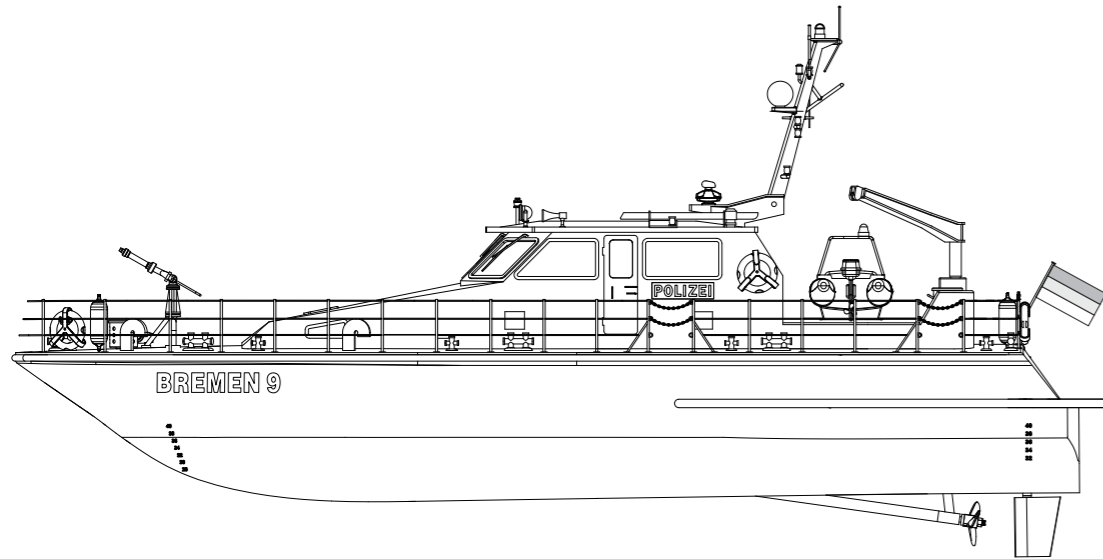

Designed by Kymodel Copyright

The final interpretation of this product is owned by Kymodel and is subject to change without notice.  
 本产品的最终解释权归Kymodel所有,如有变更,恕不另行通知。  
 February 2019

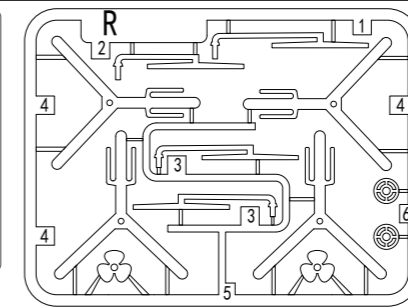
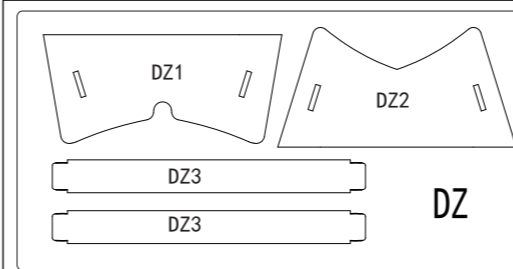

### Assembly module step Diagram 组装模块分步图

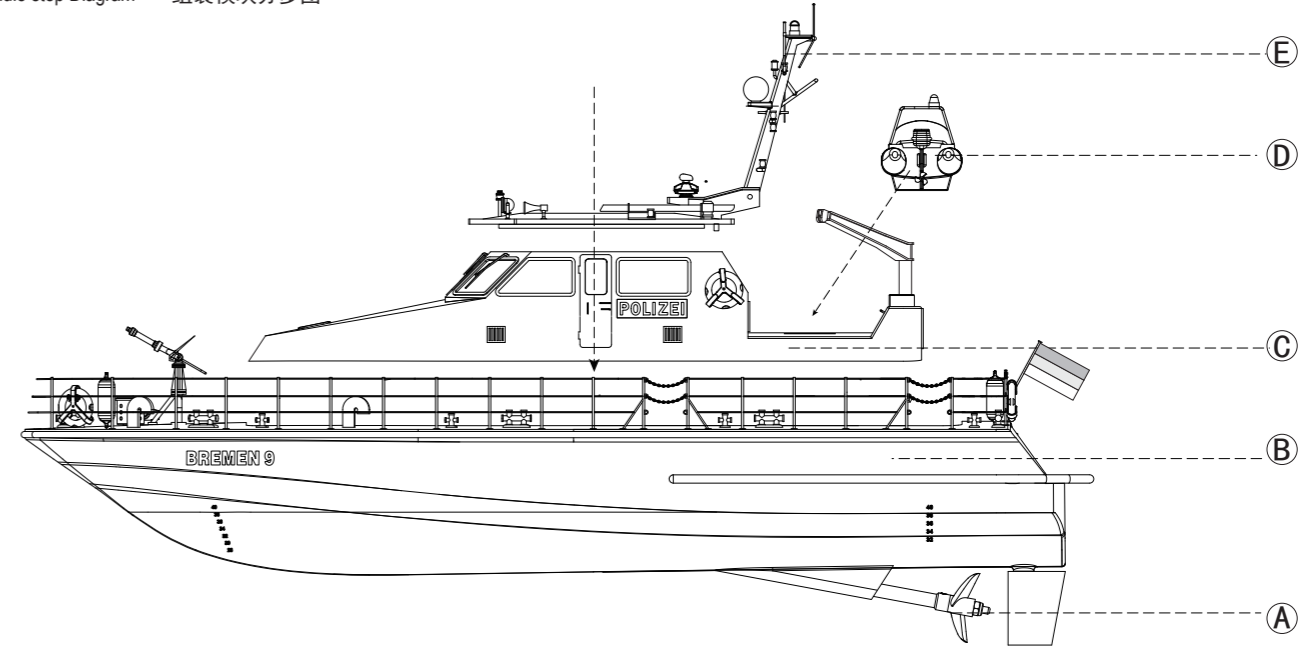

### Parts 部件

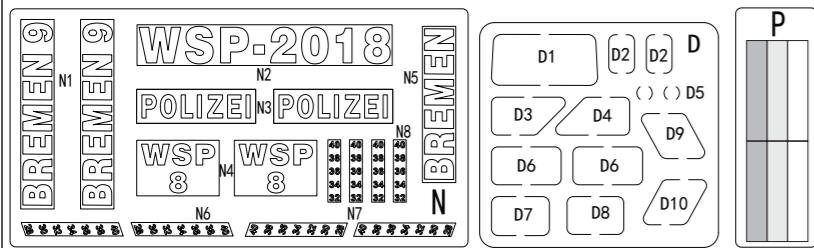
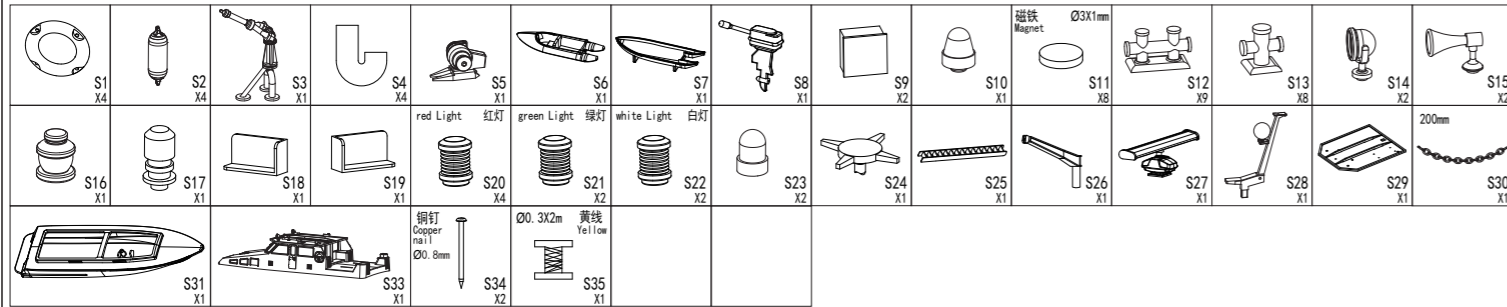

| Number (编号) | Specifications (规格)       | quantity (数量) |
|-------------|---------------------------|---------------|
| T1          | Ø1.0X100mm Brass Rod (铜棒) | 1             |
| T2          | Ø1.0X100mm Steel Rod (钢棒) | 1             |
| T3          | Ø0.8X35mm Brass Rod (铜棒)  | 1             |
| T4          | Ø0.3X100mm Steel Rod (钢棒) | 1             |
| T5          | Ø0.6X30mm Steel Rod (钢棒)  | 1             |

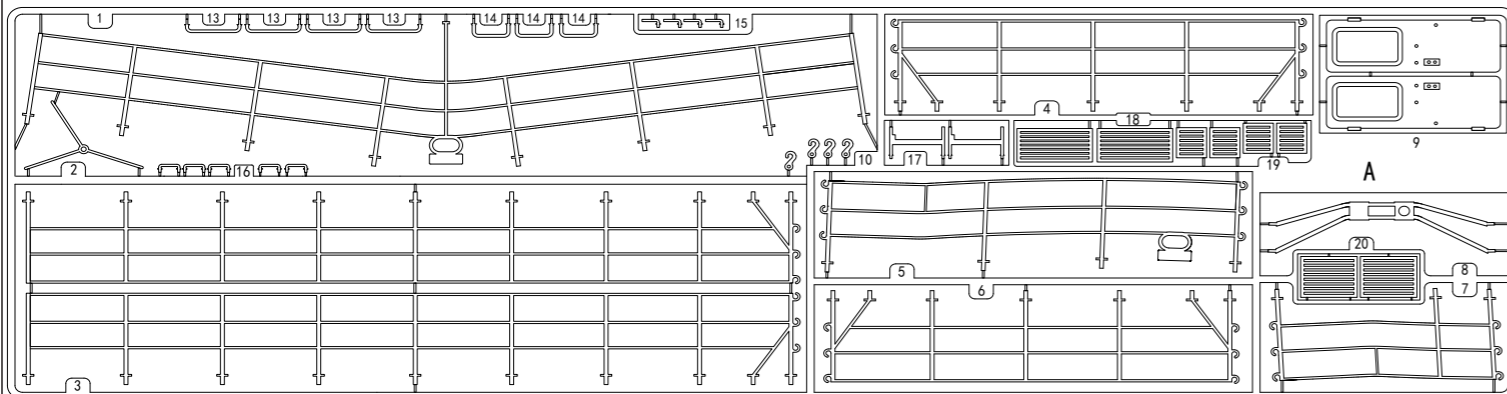

### Power unit Exploded Diagram 动力装置分解图

#### M Power unit 动力部件

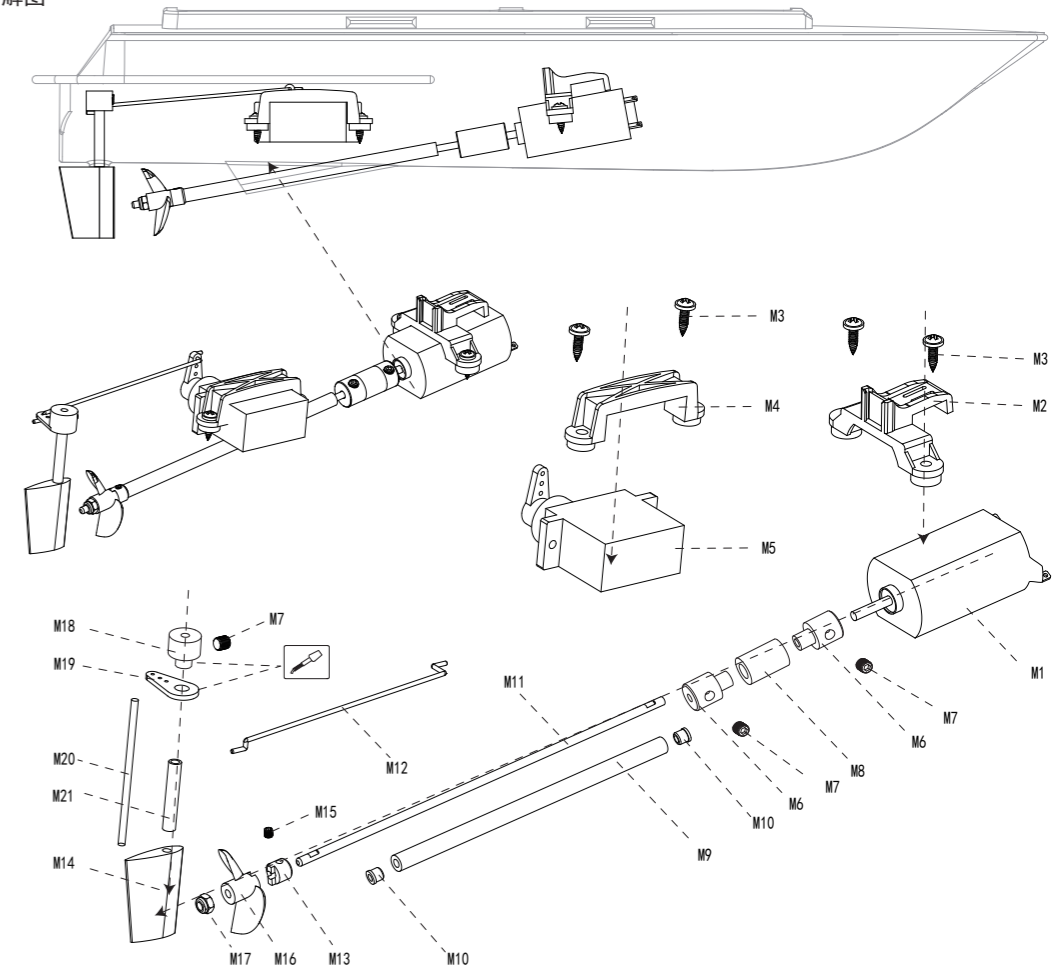
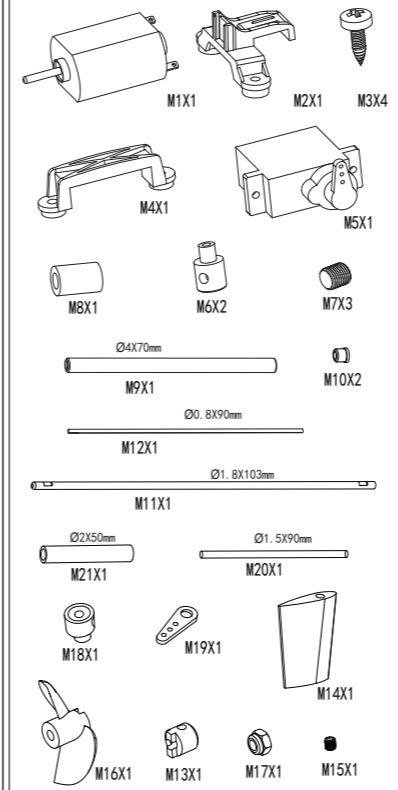

B Hull assembly Diagram 船体组装图

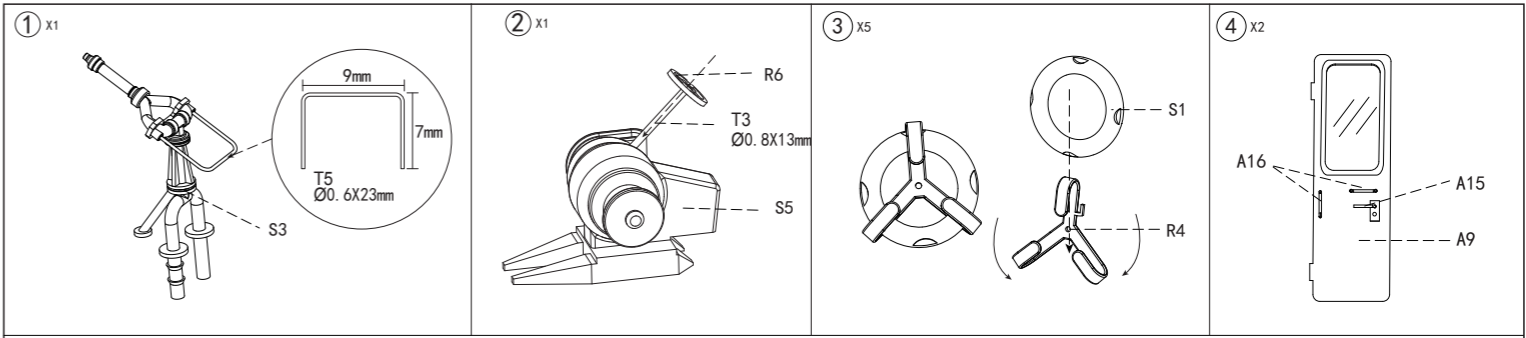
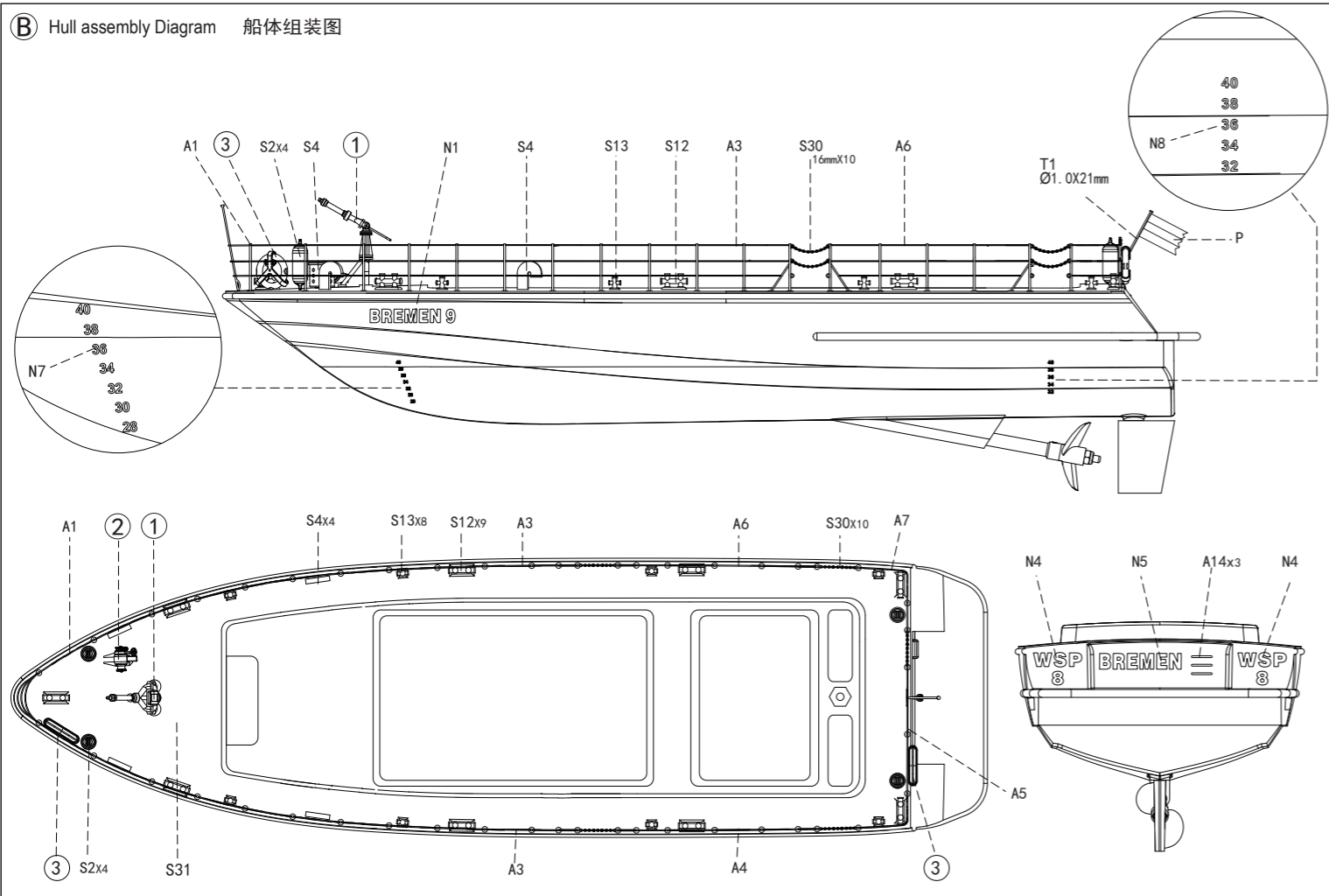

D Small Boat parts Assembly Diagram 小艇零件组装图

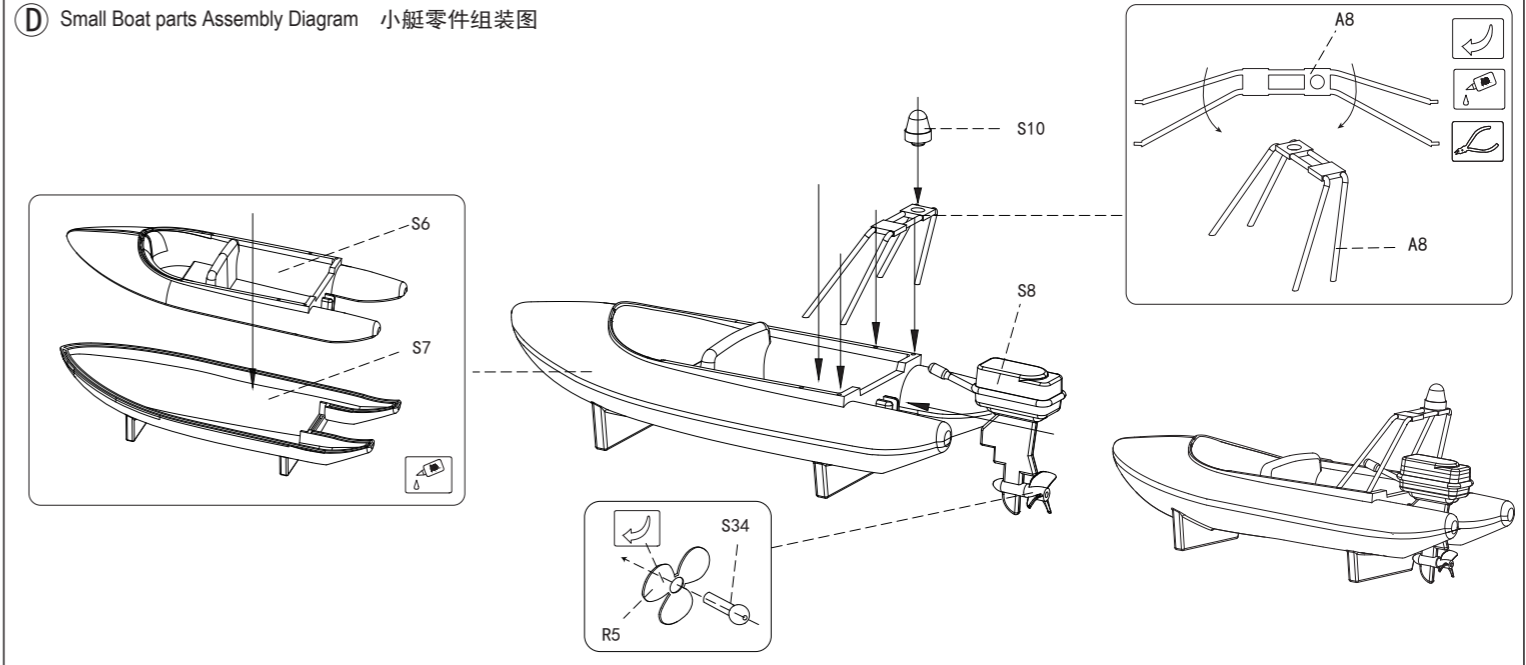

C Bridge parts Assembly Diagram 舰桥零件组装图

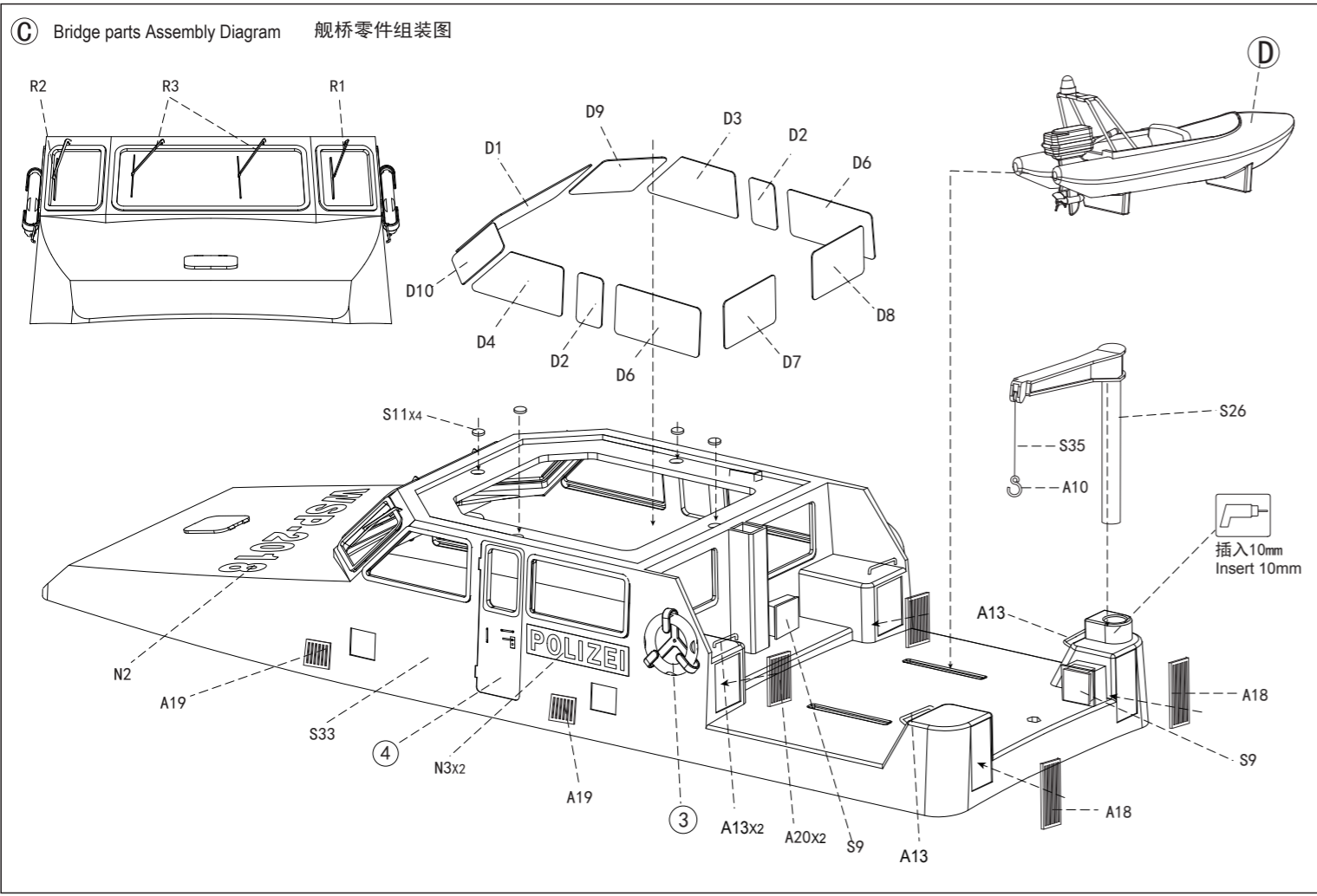

E Mast rigging Assembly Diagram 桅杆索具组装图

